



factory &
process automation
solutions

building automation
solutions



SoftDEL

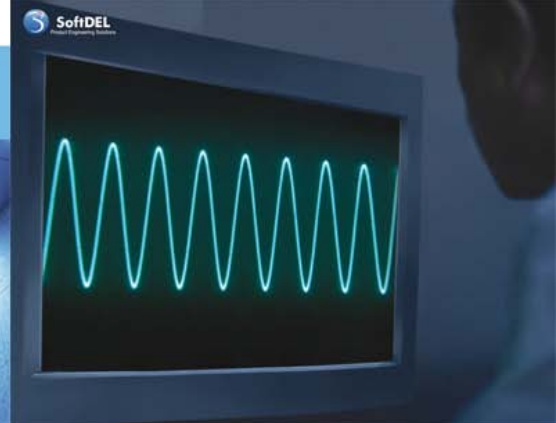

test & measurement
solutions

Partner to global industrial product companies for control & connectivity based engineering solutions.

Daughter Board Development for Programmable Thermostat

The Customer

The customer is a global leader in HVAC & refrigeration systems

Customer Needs

The customer develops various types of Programmable Thermostats that provide heating and cooling requests to HVAC equipments. The customer wanted to extend the access of these thermostat settings, configuration, and history to other HVAC system. Additionally, these settings were to be easily accessible through physical media (SD card), or through a wireless communication mode like IEEE 802, 11b/g. Z-wave, Zigbee, Bluetooth or Infrared communication.

SoftDEL Solution

The project was divided into 3 phases:

- Phase I – Development of a 1.8" x 2.0" sized ExP(Edge Expansion Port)/Daughter Board that allows an SD card to program the thermostat via an external computer. SoftDEL also developed the required firmware for the daughter board.
- Phase II – Wireless X-stream RF module interface
- Phase III – TCP/IP

Project Deliverables

- Schematic
- BOM
- Gerber & Silk screen
- SRS
- Design Document
- Code/ firmware
- Hardware test cases
- Software test cases
- Prototypes

System Overview

- **Control Module:** This module synchronizes timing, data transfer, interrupts.
- **SPI Protocol Stack:** The firmware uses the hardware SPI port pins, registers and interrupt with control signals to communicate to EERROM and SD card.
- **Customer RS232 ASCII Protocol Stack:** The firmware uses hardware RS232 TX and RX pins, registers and interrupts for the custom RS232 ASCII protocol. The settings are transferred by use of a custom ASCII protocol. Custom ASCII protocol features:
 - Configures setting to thermostat
 - Receives thermostat response to the transferred setting
 - Backup of settings from thermostat
- **Database Management Module:** Acts as store for retrieved binary files present in SD card from the thermostat. The stored SD card settings are used for thermostat configuration.
- **Low Voltage Level I/O Module:** Initializes all micro controller pin directions (states & default values) and registers that are required for enabling ports and generating interrupts.
- **Database:** Binary file present on SD card as the database. The file stores various settings that need to be configured in the thermostat. The database is created at a remote location by use of a computer and some custom client tools. The database is then put on the SD card. This SD card is then used to updating thermostat settings. The daughter board has the capability of updating database with settings that exist with thermostat. Once thermostat settings are copied to SD card, then they can be viewed on a computer by using custom client tools.
- **EEPROM:** As an additional backup

Block Diagram

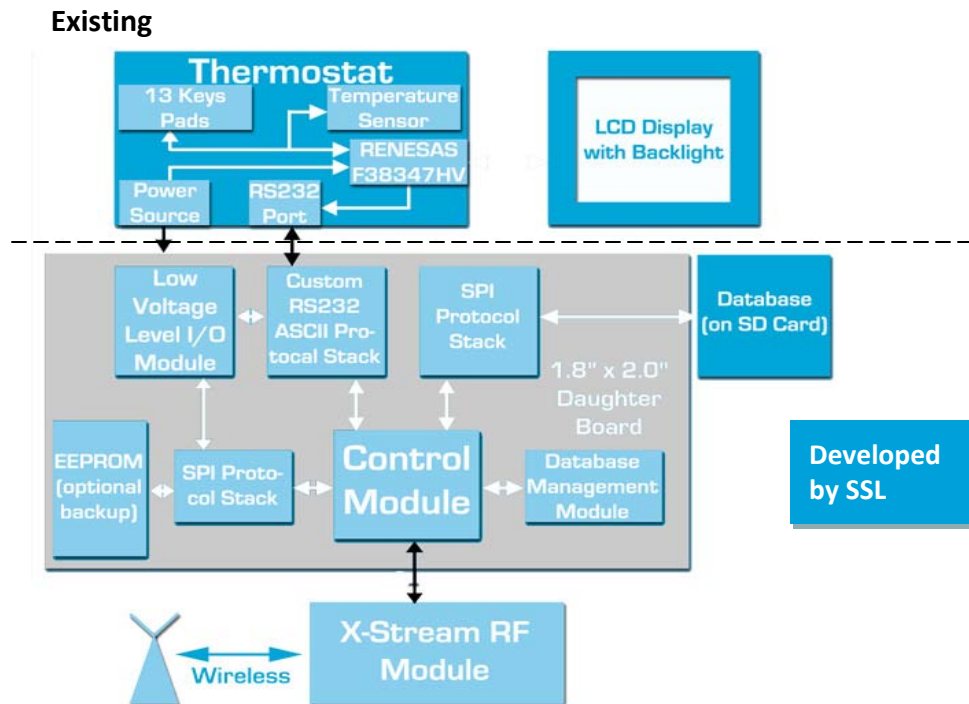

Key Features

A user friendly interface to customize various thermostat settings like

- Time and temperature schedule
- Heat/cool points
- Operating modes
- User configurable parameters

Impact

- Ready automated settings through daughter board
- Compact in size (1.8" x 2.0")
- Low power requirements (100mA current and 3.3 V DC supply)
- Secure binary file format
- Easy backup of thermostat settings
- Rapid new feature development and time to market

WWW.SOFTDEL.COM

USA
1050 Winter St. #1000
Waltham, MA 02451
+1 (832) 886 0006
info@softdel.com

India
3rd Floor, Pentagon P-4
Magarpatta City, Hadapsar,
Pune, 411028
+91 (20) 6701 0001
india@softdel.com

Japan
Nitte Bldg, 1101,
1-22-12 Shinkawa,
Chuo-Ku, Tokyo 104-0033.
Japan.
japan@softdel.com

